

REV	CHG.	DATE	DESCRIPTION	REVISION

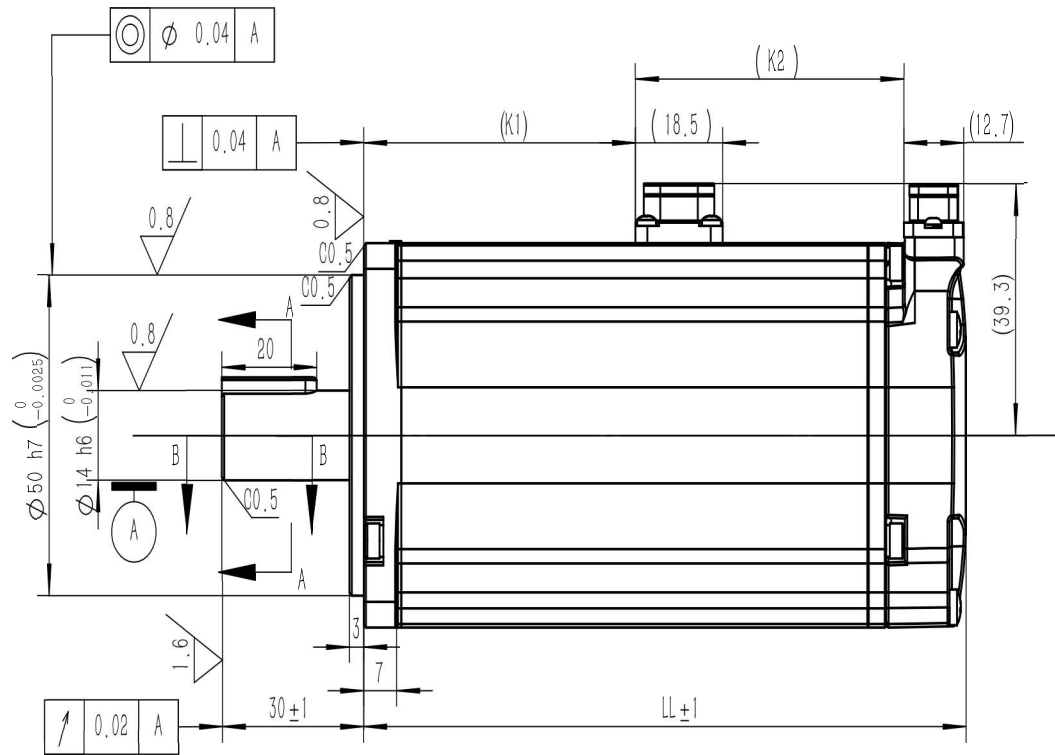

Signal	Pin No.	מחבר 2
S+	1	
S-	2	
BAT+	3	
PG 5V	4	
PG 0V	5	
BAT-	6	
FG	7	

Signal	Pin No.	מחבר 1
W	1	
V	2	
U	3	
FG	4	
Brake1	5	
Brake2	6	

מק"ט	משקל (Kg)	מידות (mm)		
		LL	K1	K2
UMM-0002BAB-B5	1.16	107	37.4	56.7
UMM-0004BAB-B5	1.56	128	57.8	57

SOURCE DRAWING-FOR REFERENCE ONLY

APPROVED BY	DATE																		
CHECKED BY	DATE																		
DRAWING BY Doron	DATE 07.05.2024																		
TOLERANCE UNLESS OTHERWISE SPECIFIED	<table border="1"> <tr> <th>CABLE LENGTH</th> <th>TOLERANCE</th> </tr> <tr> <td>ALL LENGTHS</td> <td>+4%(OR 50mm) OF LENGTH -0%(OR 0mm) OF LENGTH WHICHEVER IS GREATER</td> </tr> <tr> <th>STRIP LENGTH</th> <th>TOLERANCE</th> </tr> <tr> <td>0-7mm</td> <td>±1.0mm</td> </tr> <tr> <td>8-29mm</td> <td>±1.5mm</td> </tr> <tr> <td>30-49mm</td> <td>±2.0mm</td> </tr> <tr> <td>50-99mm</td> <td>±3.0mm</td> </tr> <tr> <td>70-100mm</td> <td>±4.0mm</td> </tr> <tr> <td>over 100mm</td> <td>±5.0mm</td> </tr> </table>	CABLE LENGTH	TOLERANCE	ALL LENGTHS	+4%(OR 50mm) OF LENGTH -0%(OR 0mm) OF LENGTH WHICHEVER IS GREATER	STRIP LENGTH	TOLERANCE	0-7mm	±1.0mm	8-29mm	±1.5mm	30-49mm	±2.0mm	50-99mm	±3.0mm	70-100mm	±4.0mm	over 100mm	±5.0mm
CABLE LENGTH	TOLERANCE																		
ALL LENGTHS	+4%(OR 50mm) OF LENGTH -0%(OR 0mm) OF LENGTH WHICHEVER IS GREATER																		
STRIP LENGTH	TOLERANCE																		
0-7mm	±1.0mm																		
8-29mm	±1.5mm																		
30-49mm	±2.0mm																		
50-99mm	±3.0mm																		
70-100mm	±4.0mm																		
over 100mm	±5.0mm																		

UNITRONICS®

UNITS	mm	DESCRIPTION:
1st Angle Projection		200VAC, 200W~400W, B5_BR
		PART NO.
REV	A	SHEET 1 OF 1